

Installation Instructions

DS794Z Long Range Passive Infrared Intrusion Detector with Self-test

1.0 General Description

The DS794Z is a high performance intrusion detector designed to provide an alarm condition upon the detection of an intruder moving into or through its coverage pattern.

Technology designed into the DS794Z is based on the transmission of infrared energy; all objects transmit infrared energy. The warmer an object is, the more infrared energy transmitted. The DS794Z detects the change in infrared energy that occurs when a target passes through its view.

The coverage pattern, consisting of sensor fingers (to detect the target) is arranged in a side-by-side array. The total number of fingers is determined by the optical module used. The fingers are grouped by polarity into pairs, with each pair consisting of one zone.

To detect motion, the DS794Z must first see a change in infrared energy in one finger followed by a change of energy in the remaining finger. Therefore, disturbances that occur in only one finger do not constitute motion and are ignored.

The "catch sensitivity" may be changed by the installer to provide a degree of sensitivity determined by each installation.

2.0 Specifications

• Coverage:

The DS794Z is shipped with the OA80 80 foot (24.4 m) Mirror installed. If a 200 foot (61 m) range is desired, it will be necessary to install the OA200 Mirror that is sent along with the unit.

Standard Range:

Broad (OA80 Mirror): 80 ft. by 50 ft. (24.4 m by 15.3 m)
Long (OA200 Mirror): 200 ft. by 10 ft. (61.0 m by 3.1 m)

Optional Range:

Long (OA120 Mirror): 120 ft. by 25 ft. (36.6 m by 7.6 m)

- **Input Power:** 6.0 to 15.0 VDC; 18 mA at 12 VDC.
- **Standby Power:** There is no internal standby battery. Connect to DC power sources capable of supplying standby power if primary power fails. Eighteen mA-H required for each hour of standby time needed. *Four hours (72 mA-H minimum) are required for UL Listed Requirements.*
- **Sensitivity:** Field selectable for Standard, Intermediate, or High.
- **Alarm Relay:** Silent operating Form "C" relay. Contacts rated 125 mA, 28 VDC maximum for DC resistive loads. *Do not use with capacitive or inductive loads.*
- **Tamper:** Normally Closed (with cover in place) tamper switch. Contacts rated at 28 VDC, 125 mA maximum.
- **Trouble Output:** A solid state open collector shorts to ground (-) when the detector is in a trouble condition. Maximum current load is 25 mA.
- **Temperature:** The storage and operating range is -20° to +120°F (-29° to +49°C). *For UL Listed Requirements, the range is +32° to +120°F (0° to +49°C).*

- **Sonalert™ Connector:** Using a Sonalert™ type sounder (low voltage) will provide an audible tone when the unit is in alarm. *A sounder is intended only as an aid for walk testing during installation.*

Sonalert™ is a trademark of Mallory.

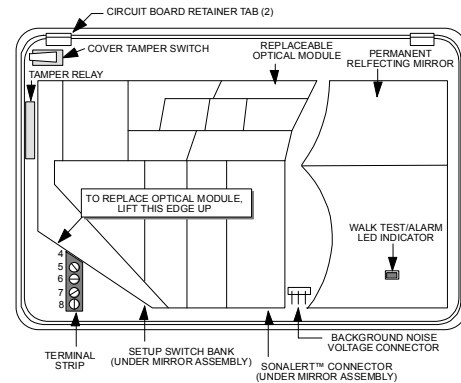

Front view with cover off

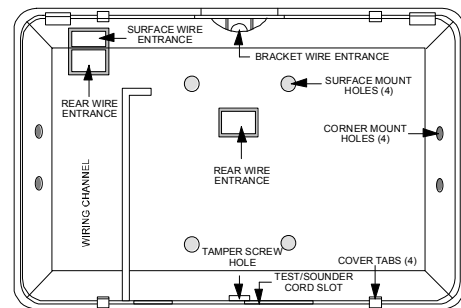

Base

- **Options:** OA120-2* Mirror and TC6000 Test Cord.

** Shipped in packages of 2.*

3.0 Mounting

Select a location likely to intercept an intruder moving across the coverage pattern (review patterns on page 4). **The recommended mounting height is 7.5 ft. (2.3 m) for the DS794Z with the OA80 or OA120 Mirror, or 10 ft. (3.1 m) for the OA200 Mirror.** Each mounting surface should be solid and vibration free. When mounting, avoid hot and cold drafts, heat sources, animals and pets and direct sunlight. Do not mount outdoors.

- Remove the cover by inserting a thin screwdriver into each of the four slots on the cover. Twist gently until the cover snaps free of the tabs on the base.

3.1 Bracket Mounting

NOTE: The use of the B334 Mounting Bracket (included) is strongly recommended when installing this detector.

Because variations exist in the surfaces of most mounting walls, most units are not mounted at perfect angles to the floor or walls. This may cause the pattern to point away from the "ideal" direction.

For example: A shift of only 1 degree will cause a pattern shift of 1.7 ft. (1.05 m) at 100 ft. (30.5 m). Under worst case conditions, this will cause the pattern to be aimed over the head of intruders at maximum range, or into walls of narrow corridors. What may seem to be poor range or catch performance, may be the result of improper alignment.

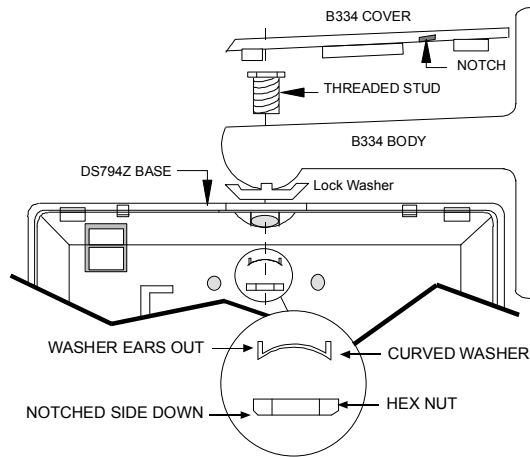

Bracket to Base Assembly



To insure proper catch performance, a bracket mounted detector permits the flexibility needed to properly adjust the direction of the coverage pattern.

If Mounting to the B334 Mounting Bracket:

- Remove the cover of the bracket by inserting a thin screwdriver into the notch on the side of the bracket and twisting gently.
- Insert the alarm and power wiring through the center hole from the rear of the B334 base. (Do not insert wiring if the bracket is to be surface mounted).
- Mount the B334 to a standard single-gang switch or outlet box using the supplied Bevel Head screws. (If surface mounting the unit, use the wall screw/anchor assemblies or appropriate alternatives).
- Remove the circuit board from its base. Press the two circuit board retainer tabs outward and lift the circuit board away from the base.
- Remove the sticker covering the entrance from the back of the detector base.
- Insert the threaded stud through the appropriate stud hole in the B334 bracket. Use the bottom hole for wall mounting or the front hole for ceiling mounting. *Make sure the hex head is seated in place.*
- Complete the assembly by securing the detector base to the B334 bracket using the supplied curved washer and hex nut (see drawing).
- Hand tighten the hex nut.
- Thread the bracket wiring through the stud and along the wiring channel in the detector's base to the area of the circuit board's terminal strip.
- Return the circuit board to its base. Slide the back of the circuit board under the tabs at the back of the base, then snap the front into place.
- Aim the detector in the desired general direction and tighten the hex nut using the supplied hex wrench.
- Should the detector require realignment, loosen the hex nut, reposition the detector, and then retighten the nut.

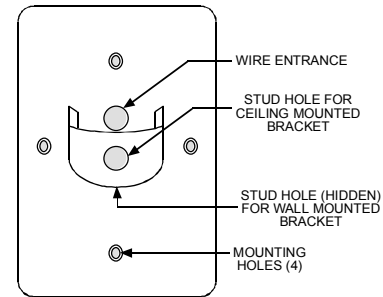

B334 Bracket

3.2 Surface or Corner Mounting

- Remove the circuit board from its base. Press the two circuit board retainer tabs outward and lift the circuit board away from the base.
- Select and break away the appropriate thin-wall wire entrance covering the detector base.
- Using the base as a template, mark the location of the mounting holes on the mounting surface. Pre-start the mounting screws.
- Route the wiring to the rear of the base and through the wire entrance. Firmly mount the base to the mounting surface.

NOTE: Be sure all wiring is unpowered (de-energized) before routing.

- Return the circuit board to its base. Slide the back of the circuit board under the tabs at the back of the base, then snap the front into place.

4.0 Wiring



ONLY APPLY POWER AFTER ALL CONNECTIONS HAVE BEEN MADE AND INSPECTED.

NOTE: Do not coil excess wiring inside unit.

Locate the two-piece terminal strip on the side of the circuit board assembly. Remove the wiring connector from the terminal strip by inserting a screwdriver between the wiring connector and terminal strip, and gently prying apart.

- **Terminals 1 (-) & 2 (+):** Power limits are 6 to 15 VDC. Use no smaller than #22 AWG (0.8 mm) wire pair between the unit and the power source.
- **Terminals 3, 4, & 5:** Alarm relay contacts rated 125 mA, 28 VDC maximum for DC resistive loads. Use terminals 4 & 5 for Normally Closed circuits. *Do not use with capacitive or inductive loads.*
- **Terminals 6 & 7:** Tamper contacts rated at 28 VDC, 125 mA.
- **Terminal 8:** Trouble. Solid State Trouble output. Shorts to ground (-) when the detector is in a Trouble condition.

Re-install the wiring connector to the terminal strip.

5.0 Configuration Switch Settings

The DS794Z has several features that are controlled using the configuration switches.

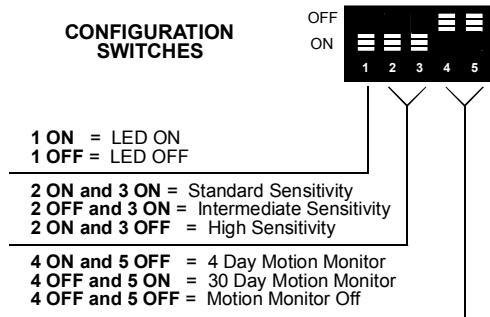

5.1 LED Operation (S1)

- **ON:** Allows the Alarm/Test LED to operate when activated by motion.
- **OFF:** The LED will not operate on alarm activation, but will indicate a supervision trouble condition.

5.2 Sensitivity Mode (S2 and S3)

Sensitivity modes depend on the type of coverage desired and the installation environment.

- **Standard Sensitivity:** The recommended setting for the DS794Z with the 80 ft. (24.4 m) Mirror installed. Tolerates environment extremes on this setting. *Not recommended for the 120 ft. (36.6 m) and 200 ft. (61 m) coverages.*
- **Intermediate Sensitivity:** The recommended setting for the 120 ft. and 200 ft. (36.6 m and 61 m) coverages or for locations where an intruder is expected to cover only a small portion of the protected area. Tolerates normal environments on this setting.
- **High Sensitivity:** The setting for fast response to intruder signals. For use in quiet environments where thermal and illumination transients are not anticipated.

If both switches are in the Off position, the unit will default to the Intermediate setting.

NOTE: Although the sensitivity modes provide different degrees of tolerance to environmentally caused alarms, the installer should assure peak background noise voltage readings do not exceed ± 0.15 VDC. (See Section 8.0 Final Tests).

5.3 Motion Monitor (S4 and S5)

Set switches S4 and S5 for the desired Motion Monitor time (see Supervision Features). **The detector is shipped with the Motion Monitor feature Off.**

6.0 Supervision Features

The DS794Z performs several supervision features that, combined with the advanced motion detection capabilities of the detector, provide an extremely high level of security. A supervision trouble condition is indicated at the detector by the Alarm/Test LED (see the Supervision Display Chart).

- The LED indicates the cause of the supervision trouble once per second using coded pulses. The supervision trouble signal activates the Trouble Output available on terminal 8.

The supervision features function as follows:

- **PIR:** The operation of the PIR is electronically checked approximately every 12 hours. If the PIR fails, the Alarm/Test LED will flash 4 times and the Trouble Output will activate.
- **Motion Monitor Supervision:** This feature verifies that the detector has a clear view of the detection area. When selected using switches S4 and S5, a supervision timer is activated. A trouble condition will be indicated if the detector has not alarmed at least once during the selected time period (this feature can be disabled by placing both switches in the Off position). The time period selected should be long enough to allow adequate time for holiday weekends.

Refer to Section 5.0 (Configuration Switch Settings) for proper switch settings.

If the time period selected has elapsed from the last alarm, the LED will flash 2 times and the Trouble Output will activate.

It is recommended that the 30 day timer be selected. This verifies that the unit is operational and avoids nuisance trouble conditions caused by holidays, vacations, etc.

Supervision Display Chart

LED	CAUSE
ON	Unit Alarm
Flashing 2	Motion Monitor Timeout
Flashing 4	PIR Self-test Failure

7.0 Setup and Walk Testing

If a different optical module is to be used:

- Slide the current module free from its housing. Install the new optical module onto the housing. Make sure it snaps into place.

NOTE: Excessive handling of the front mirrored surfaces may lead to performance degradation.

- Replace the front cover.

NOTE: All testing must be performed with the front cover in place.

- Apply power to the unit.
- Wait at least two minutes, after applying power, to start walk tests. For best results, wait at least 1 minute between walk tests to allow the processing to adjust to the background.

NOTE: Walk testing should be done across the coverage pattern as shown.

- The edge of the coverage pattern is determined when the Alarm/Test LED indicator (and optional Sonalert™, if installed) first turns on.

NOTE: The use of a Sonalert™ type device (sounder) will provide an audible tone during the time the unit is in alarm. Of the three available connector pins, the center pin is positive (+) with respect to either outside pin (outside pins are common (-)).

Sonalert™ is a trademark of Mallory.

Walk test the unit from all directions to determine the boundaries.

- After completion of the walk tests, remove the Sonalert™ (if installed).

8.0 Final Tests

NOTE: Meter readings are very important in determining back ground disturbance levels and catch margin sensitivity.

- Connect a 20,000 ohm/volt (or greater) DC VOM to the Noise Voltage connector pins as shown. Set meter scale for about 3 VDC. Route meter wiring through the slot in the base. (Use of the TC6000 is recommended, but is not essential for meter use.)
- The base reference level for reading background noise or target voltages is approximately 2.0 VDC. Installations in quiet environments, therefore, will result in a steady meter reading between 1.9 and 2.1 VDC.

Voltage changes greater than 0.75 VDC from the reference level are desirable for good catch performance. If changes are less than ± 0.75 VDC, the device may fail to respond at this distance if the temperature difference between the intruder and the background is very small.

- Turn on all heating and cooling sources that would normally be in operation during times of protection. Stand away from the unit and outside the coverage pattern, then monitor the background noise for at least **three minutes**.

DS794Z readings should not deviate from the reference level more than ± 0.15 VDC. For readings outside these limits; eliminate the cause, re-point the unit slightly, or mask off the affected zones.

9.0 Other Information

9.1 LED Indicator Operation

- If viewing the operation of the Alarm/Test LED indicator is not desired *after* setup and walk tests are completed, place configuration switch S1 in the Off position.

9.2 Sealing the Wire Entrance

- The foam plug that is provided with the unit is for sealing the wire entrance from drafts and insects.

9.3 Maintenance

- At least once a year, the range and coverage should be checked according to Sections 7.0 and 8.0 (Walk Testing and Final Tests).
- To ensure continued daily operation, the end user should be instructed to daily walk through the far end of the coverage pattern. This assures an alarm output prior to arming the system.

9.4 Mirror Module Information

- Should the mirror surfaces become soiled or dirty, clean using a soft clean cloth and any commonly available mild window cleaner.

9.5 Masking

- Refer to the mirror module and pattern drawings for masking information.
- Before attempting any masking, be sure the chosen mirror surface is the correct one. When attempting to remove any masking, many adhesives will either destroy the mirror's surface or leave enough residue behind to reduce coverage performance.
- Shaded areas of the mirror drawings do not affect the pattern and, therefore, are not maskable.

9.6 U. S. Patent Numbers

- The DS794Z is protected by the following U. S. patents: #4,764,755, #4,920,268, and #5,083,106.

10.0 Coverage Patterns

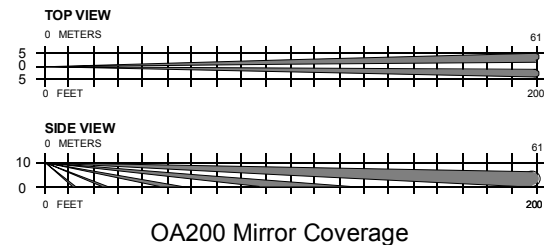
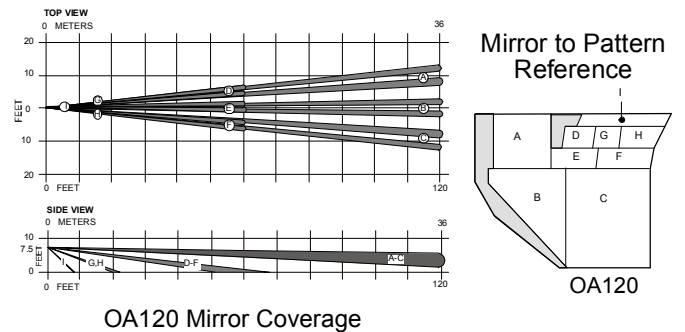
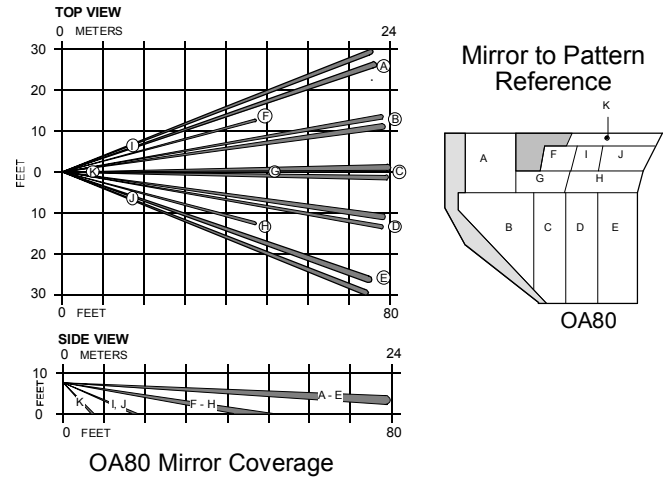

Mirror to Pattern Reference

