

**ACTIVE IR SENSORS RN4 10-25/25-75/75-150**

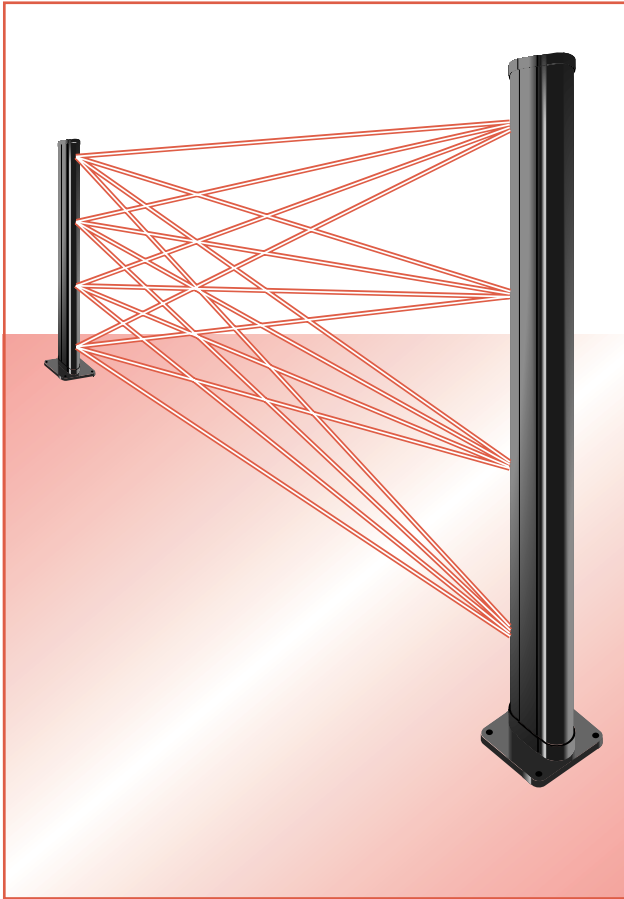

**FEATURES**

- Sixteen active beams
- Field adjustable detection levels
- 10 metres to 150 metres external ranges
- No hardwire synchronisation
- Integral head heaters
- Graded alarm response
- Fog detection circuitry
- High power transmission
- Modular system design
- Wall mountable or free standing

**CONCEPT**

The Rednet® series of photobeams is a range of active infrared detectors designed to combine high levels of intruder detection with a low potential for false activation. The system utilises the infrared transmission to synchronise transmitters and receivers and removes the need for hardwire synchronisation cables between towers. RN4 systems feature four high power transmitters and four receivers. Uniquely, each transmitter operates to all receivers and all receivers are operated by all transmitters. This combination creates a sixteen beam path 'net' which is difficult to compromise.

**OPERATION**

The RN4 series relies upon the beam of infrared light created by the transmitter to fully cover all four receivers and for all receivers to be able to view all of the transmitters. This results in a minimum operating distance of 10 metres with a maximum of 150 metres.

**GRADED ALARM RESPONSE**

Rednet® graded alarm response is a technique to reduce false alarms while maintaining high levels of detection. The system continuously monitors the sixteen individual beam paths and when an object larger than the distance between adjacent beam heads is detected a 'quick' response time of 40 milliseconds is employed. However, should any single beam be broken the required beam break time is automatically applied. This slow response can be set between 0.8 seconds and 1.5 seconds depending on the level of detection required. This technique allows the system to detect both rapidly moving upright intruders and attempts to crawl through lower beams, while reducing false alarm levels from birds and blowing debris.

**SYSTEM CONFIGURATION**

Five main components are all that is required to produce a system for potential installations. Two beam tower enclosures are available. RNT175 is a free standing, double sided tower while the RNW175 is a single sided wall mounted tower enclosure. Following the installation of the towers and cabling the modular Rednet® beam set can be installed. Top tamper kits, mounting bracketry and power packs can be added to increase security and simplify installation.

**ACTIVE IR SENSORS RN4 -10-25/25-75/75-150**

**FOG DETECTION**

Each beam set comes complete with fog detection circuitry which constantly monitors the incoming infrared signal at the receiver. Should this signal deteriorate to a critical level over a period of time, a separate relay output is energised to indicate a reduction in signal strength.

**The RN4 modular beam sets contain:**

- 4 x Transmitting heads with integral heaters pre-wired to transmitter controller
- 4 x Receiving heads with integral heaters pre-wired to receiver controller
- 2 x Thermostats
- 1 x Visual alignment tester
- 1 x Fixing kit for beams and towers
- 1 x RN TEST alignment tester

**BEAM CONFIGURATION**

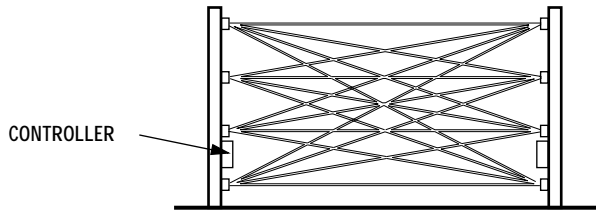

Head Positions within the towers can be varied to accommodate uneven ground. Free standing towers RNT175 allow beams to be mounted back to back with an unobstructed 360 degree view.

**DIMENSIONS**

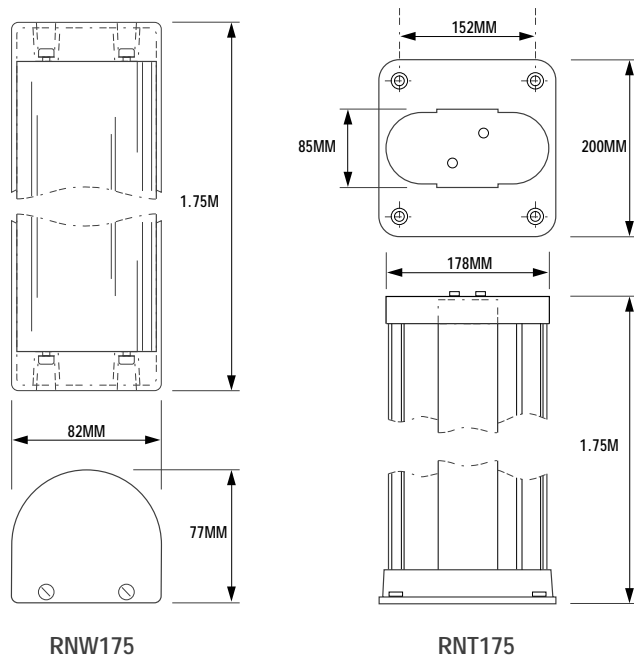

**TYPICAL LAYOUTS**

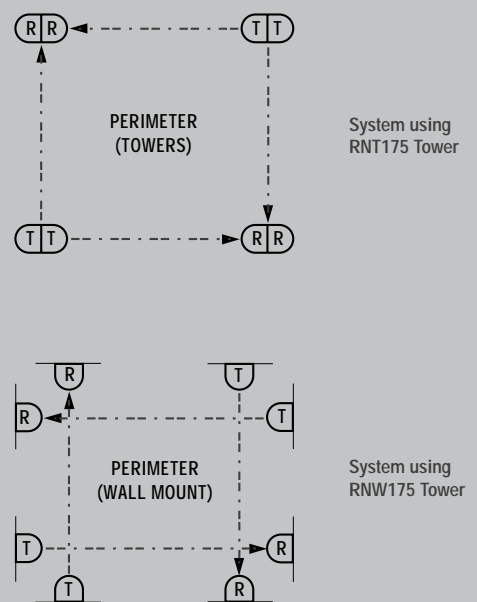

**ACCESSORIES**

RNPP 240 V	220/240 V AC 55-0-55 V AC Transformer
RNPP 55 V	55-0-55 V AC-12 V AC/12 V DC with Standby Battery
RNPK	Scaffold Pole Mounting Kit
RN TEST	Rednet electronic alignment tester
RNTT	Top Tamper (Anti-Climb Kit)
RNBB	Base Bracket (to set into concrete base)
RNFAN	High Temperature Installation

For multiple installations a special 'B' frequency can be supplied to prevent interference between sets.

**SPECIFICATIONS**

Model	RN4-10/25	RN4-25/75	RN4-25/150
External Range	10M to 50M	25M to 75M	50M to 150M
Operating system	Modulated IR - 4 channel PPC (Pulse Positioning Coding)		
Supply voltage	12 V DC		
Current Consumption	70mA per Set		
Heaters	Voltage 12 DC/AC - Current 800mA per set		
Operating Temperature	-25°C - +60°C		
Alarm Output	Form C Relay 1A @ 24 V DC		
Fog Output	Form C Relay 1A @ 24 V DC		
Tamper Output	Form C Microswitch		



This unit is designed to detect intrusion and initiate a signal to control equipment. It is not a burglar/theft prevention device and we cannot accept responsibility for any losses should they occur. Due to continued improvement specifications are subject to change without prior notice.